

# TECHNICAL DATA – DOORS

# EP & EH SERIES

## ENGINEERING DETAILS for STANDARD SERIES EP & SERIES EH Embossed Six Panel 1-3/4" Doors

### Specifications

1. Doors shall be formed of one 18 gage A40 or A60 Galv. steel sheet per ASTM A 924 and A653 and shall be 1-3/4" thick.
2. EP Series Doors shall have a core of rigid Polystyrene, securely bonded to both face sheets developing a dense uniform structure of high insulation value and thermal barrier qualities, structural strength, impact resistance and sound retardation. The core shall have a nominal density of 1 #/ft<sup>3</sup>, with an "R" factor of 7.12. The door panel shall develop a "U" factor of 0.14.
3. EH Series Doors shall have a one piece kraft honeycomb core securely bonded under heat and pressure to both face sheets to reinforce, stiffen, and sound deaden the door. Honeycomb core shall have 1" to 1.2" hexagonal cells for maximum strength and shall be impregnated with phenolic resin to resist moisture, decay, fungus and rot.
4. Doors shall have vertical mechanical interlocking seams on hinge and lock edges. There shall be no seams on the faces of door.
5. Exterior doors shall be capped to retard moisture penetrating the door.
6. All hinge reinforcements shall be 3/16" thick.
7. All doors shall be internally reinforced with a 12 gage plate both sides of the door for application of surface applied door closures and holders.
8. Glass light shall be Pioneer standard steel vision lite kit , with no exposed screws on the secure side of door.
9. All doors shall be cleaned and given one coat of rust-inhibitive metal primer in compliance with ANSI A 250.10-2004
10. Doors shall be packaged to minimize damage in transit and handling.
11. UL or WHI classification mark (label) available.
12. Door construction complies with ANSI A250.8-2003 (SDI 100)
13. Hardware reinforcements are in accordance with ANSI A 250.6-2003. Locations are in accordance with ANSI/BHMA A156.115.



### Insulation Values

Factor	Definition																				
K	The rate at which heat flows thru a material. Values for insulation are normally based on one inch thickness of a single homogeneous material and are expressed in BTU/ft <sup>2</sup> /°F/hr/inch.																				
C	The rate at which heat flows thru a material of any given thickness. The "C" factor at one inch = "K" factor. The "C" factor of the same material at three inches is 1/3 of the "K" factor; at two inches the "C" factor is 1/2 the "K" factor.																				
U	The overall coefficient of heat transfer (conductivity) for all elements of construction (as well as environmental factors). A "U" factor is determined by adding the "C" factors of the various individual materials making up the composite structure. Units are expressed as BTU/ft <sup>2</sup> /°F/hr.																				
R	A measure of the resistance to heat flow. As the thickness of the insulation material increases, the resistance to the heat flow increases. See the following common insulation materials for typical "R" factors:																				
	<table border="1"> <thead> <tr> <th>Material</th> <th>1" thick</th> <th>2" thick</th> <th>3" thick</th> </tr> </thead> <tbody> <tr> <td>Urethane</td> <td>7.0</td> <td>13.0</td> <td>20.0</td> </tr> <tr> <td>Polystyrene</td> <td>4.1</td> <td>8.0</td> <td>12.0</td> </tr> <tr> <td>Fiberglass (1# or less)</td> <td>4.0</td> <td>8.0</td> <td>12.0</td> </tr> <tr> <td>Vermiculite</td> <td>2.0</td> <td>3.6</td> <td>5.5</td> </tr> </tbody> </table>	Material	1" thick	2" thick	3" thick	Urethane	7.0	13.0	20.0	Polystyrene	4.1	8.0	12.0	Fiberglass (1# or less)	4.0	8.0	12.0	Vermiculite	2.0	3.6	5.5
Material	1" thick	2" thick	3" thick																		
Urethane	7.0	13.0	20.0																		
Polystyrene	4.1	8.0	12.0																		
Fiberglass (1# or less)	4.0	8.0	12.0																		
Vermiculite	2.0	3.6	5.5																		

**TECHNICAL DATA – DOORS**

**EP & EH SERIES**

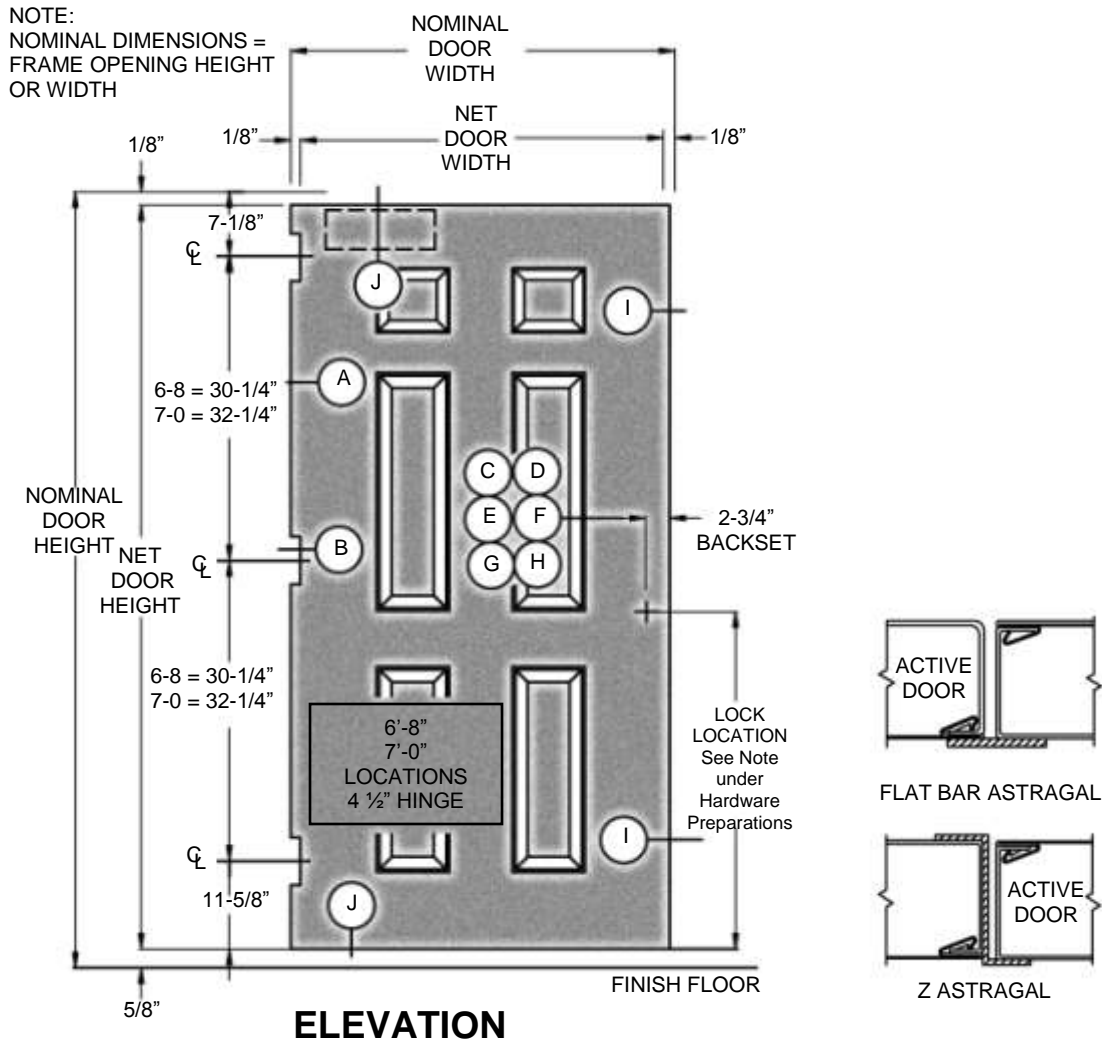

STANDARD SIZES		
DOOR OPENING HEIGHT	DOOR OPENING WIDTH*	
	SINGLE	PAIR
6' - 8"	2' - 8"***	5' - 4"
7' - 0"	2' - 10"	5' - 8"
	3' - 0"	6' - 0"

\* For other sizes consult factory.  
\*\* Cylindrical (CYL) Lock Preparation only.

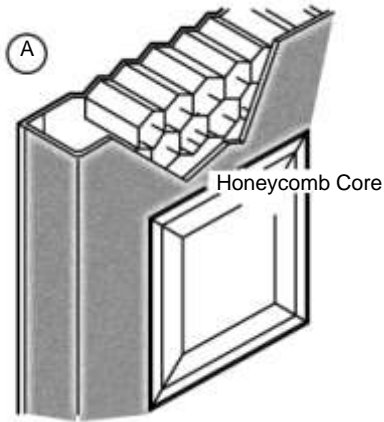

EH SERIES INTERNAL CONSTRUCTION

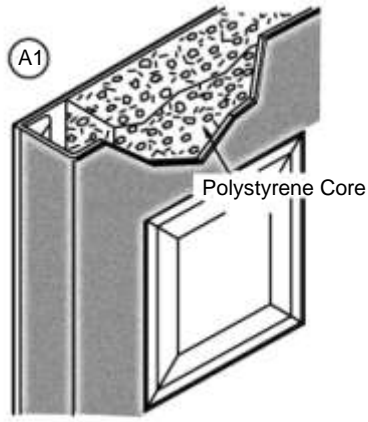

EP SERIES INTERNAL CONSTRUCTION

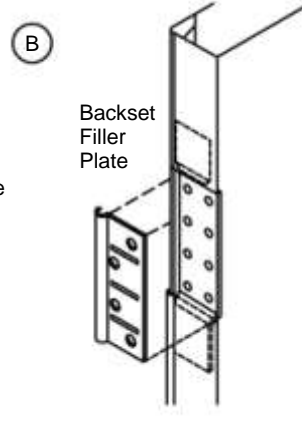

STANDARD HINGE REINFORCEMENT

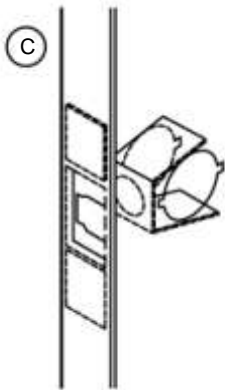

GOV'T. 161  
CYLINDRICAL (CYL)  
LOCK PREPARATION

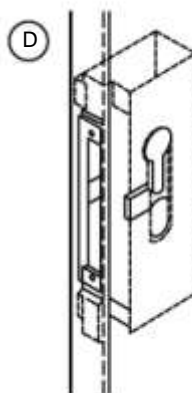

GOV'T. 86/MORTISE (M)  
LOCK PREPARATION

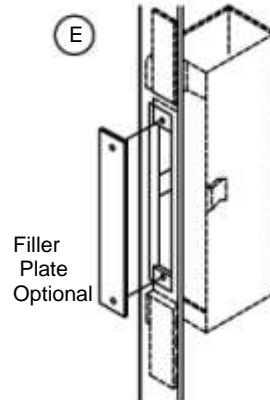

MULTI-PURPOSE(MP)  
PREPARATION

**TECHNICAL DATA – DOORS**

**EP&EH SERIES**

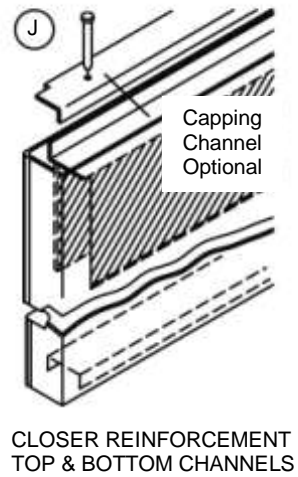
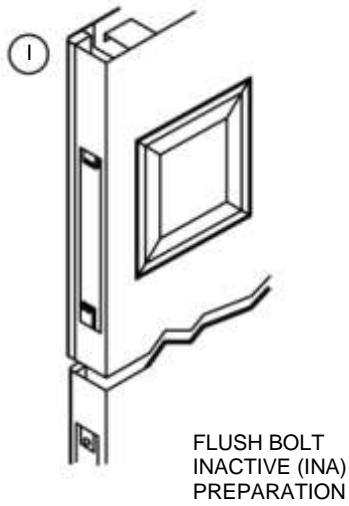
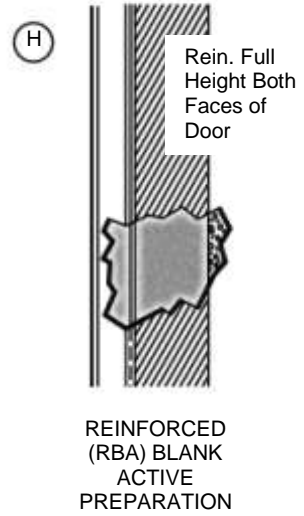
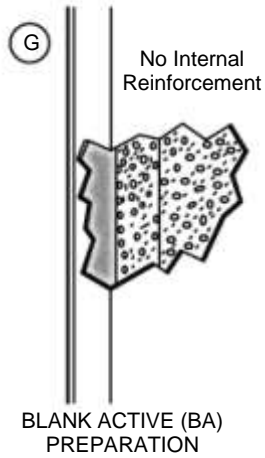
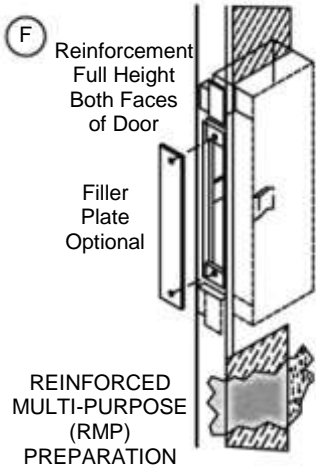

---

**STANDARD HARDWARE PREPARATIONS****HINGES:**

Series EP & Series EH Doors are mortised and reinforced for application of regular weight (0.134) or heavy weight (0.180) 4-1/2" x 4-1/2" full mortised template butt hinges; 1-1/2 pair @ 6'8" & 7'0"

**LOCKS****Active Doors to be prepared as follows:**

1. Gov't 161 cylindrical (CYL) Lock/Latch with 2-3/4" backset.
2. Universal Gov't 86 Mortise (M) Lock/Latch (to be used with full escutcheon trim) with 2-3/4" backset.
3. Multi-purpose (MP) preparation consisting of a Gov't 86 edge preparation with lock reinforcement installed. No cutouts on the faces of the door.
4. Reinforced Multi-purpose (RMP) preparation consisting of Gov't 86 edge preparation with lock reinforcement installed. The lock stile to be reinforced full height of the door on both sides. The hinge stile is reinforced on both faces at panic device height. No cutouts on the faces of the door.
5. Blank Active (BA) preparation provides a totally blank lock stile no lock preparation and no internal reinforcements. No cutouts on edges or faces of the door.
6. Reinforced Blank Active (RBA) preparation provides a totally blank lock stile — no lock preparation. The lock stile to be reinforced full height of the door on both sides. The hinge stile is reinforced on both faces at panic device height- No cutouts on the faces of the door.

**Inactive Doors to be prepared as follows:**

1. Inactive (INA) preparation consisting of two ANSI A156.115 flushbolts - 12" top and bottom rod dimension on doors up to and including 7'-2". 12" bottom and 18" top on doors over 7'-2" and up to and including 7'-6" and 12" bottom and 24", 36" or 48" top as required for doors over 7'-6". A 12" top rod dimension is optionally available on 7'-10" and 8'-0" doors. Inactive door is provided with an ASA 4-7/8" strike preparation (no lip cutout - to maintain reversibility of door). Net door width is 1/8" greater than active door.
2. Blank Inactive (BI) preparation provides a totally blank lock stile — no lock preparation and no internal reinforcements. No cutouts on edges or faces of the door. Net door width is 1/8" greater than active door.
3. Reinforced Blank Inactive (RBI) preparation provides a totally blank lock stile — no lock preparation. The lock stile to be reinforced full height of the door on both sides. The hinge stile is reinforced on both faces at panic device height No cutouts on faces of the door. Net door width is 1/8" greater than active door.

**LOCK LOCATION:** All locks located to conform to standard 38" of strike on frame.

**CLOSERS AND HOLDERS:** All Series EP & Series EH Doors are reinforced internally both sides of the door for application of most types of surface applied closers and holders. A 12 Ga. reinforcement plate 4-1/2" high measured from top of door and 16" long measured from a point 1-7/8" from the door jamb will accommodate most of the door closers currently manufactured and used on hinge side installations.

**NOTES**

In order to provide our customers with the finest products, manufactured in the most up to date manner, Pioneer Industries reserves the right to make design or specific construction changes without notice.

Doors are individually cartoned in corrugated card-board and banded with straps. Door are prime finished. Factory pre-finished doors are optionally available.

Doors are reversible, within the limits of the type and application of the required hardware. Handed doors, for any application, are optionally available.

Pairs of doors are furnished as two individual doors.

Fire Rated Doors — See Fire Rated Section for critical Information and details.